

# SensoWash<sup>®</sup> Starck C

---

**Montageanleitung**

**Mounting instructions**

**Notice de montage**

**Montageaanwijzing**

**Istruzioni di montaggio**

**Instrucciones de montaje**

**Instruções de montagem**

**Montaj kılavuzu**

**Монтажная инструкция**

**安装说明**

**据付方法**

**시공 설명서**

# 610001 .....

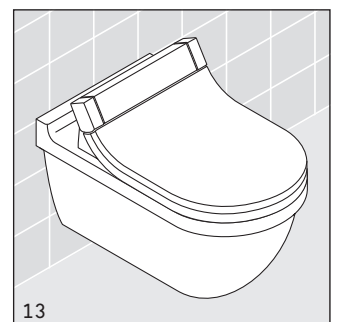
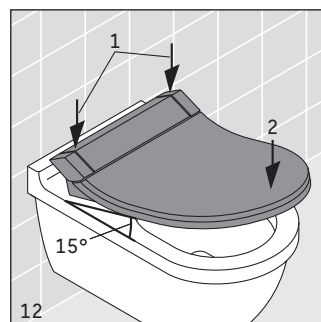
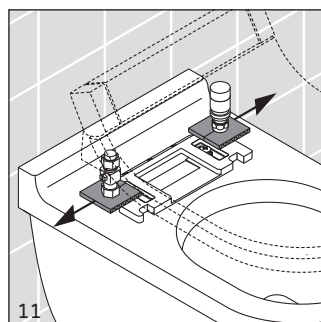
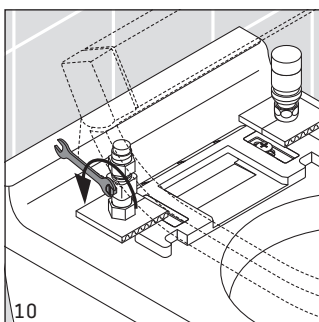
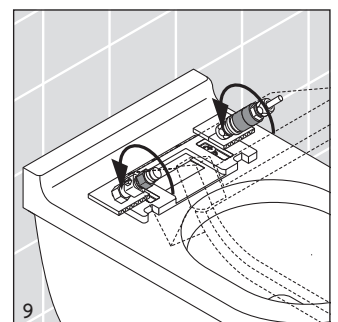
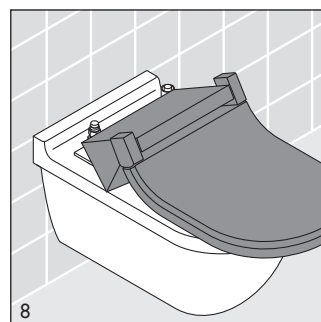
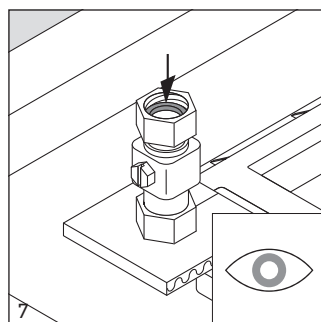
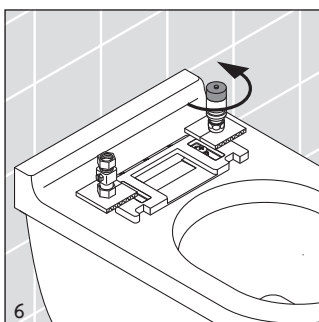
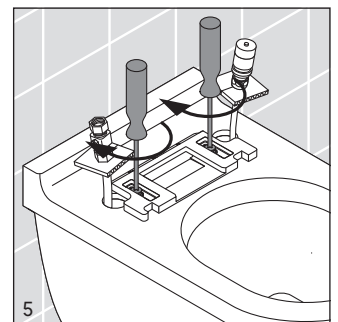
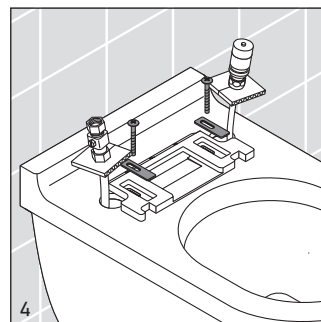
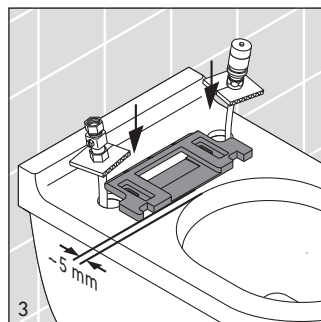
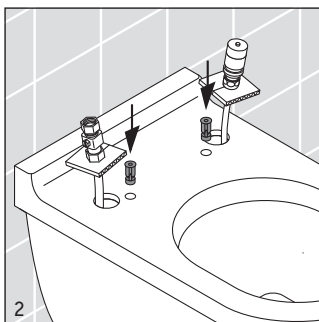
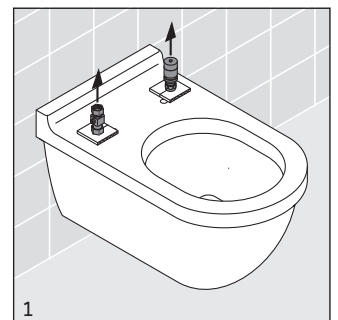
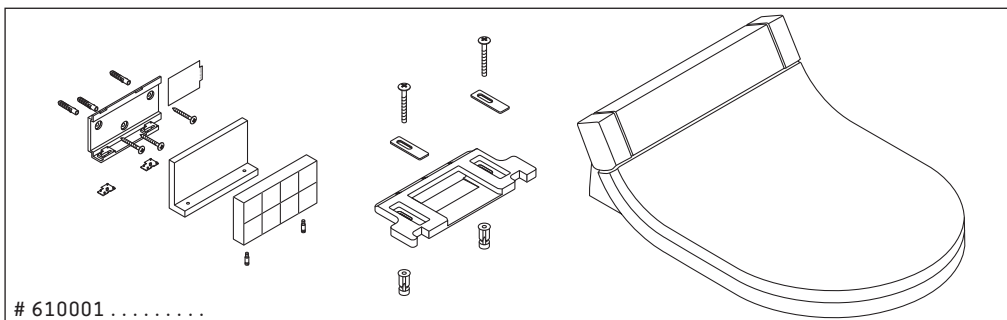

Sitz abnehmen  
Take off seat  
Enlever l'abattant  
WC-zitting afnemen

Smontare il sedile  
Quitar el asiento  
Retirar o assento  
Kapađı çıkartmak

Снять сиденье.  
取出盖  
便座を取り外して下さい。

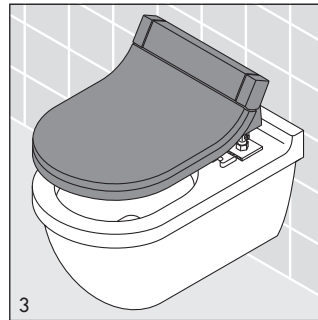
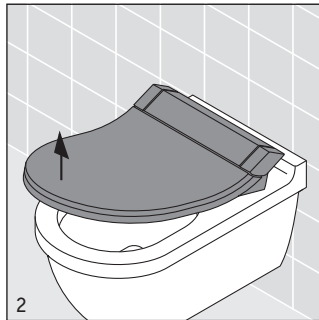
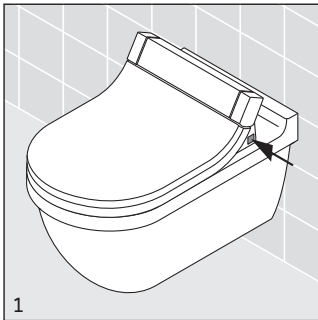

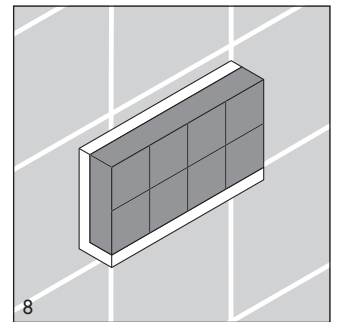
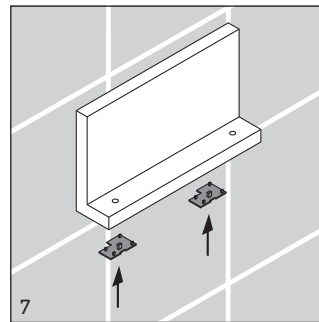
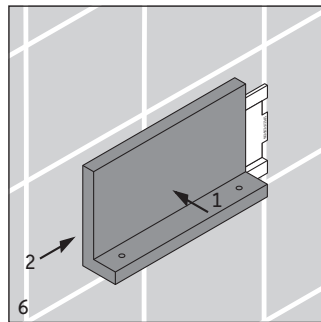
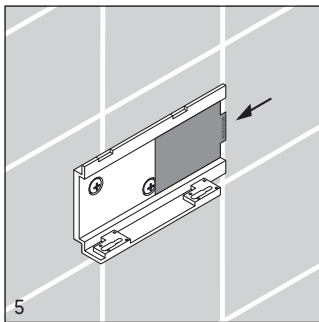
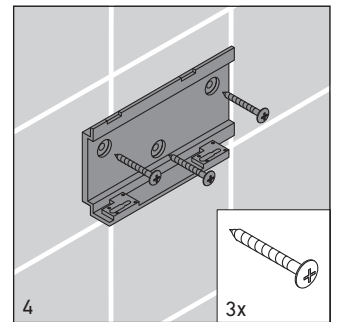
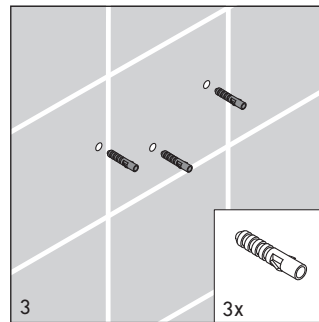
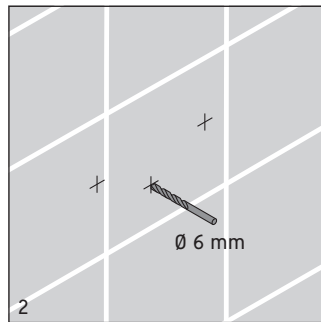
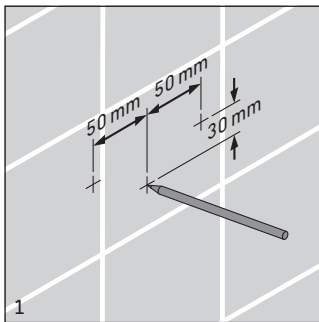



Diebstahlschutz für halböffentliche und öffentliche Bereiche.

Theft prevention for semi public and public areas.

Dispositif antivol pour espaces parapublics et publics.

Diefstalbeveiliging voor openbare en semi-openbare ruimtes.

Dispositivo antifurto per i settori pubblico e semipubblico.

Protección antirobo para el sector público y semipúblico.

Sistema anti-roubo para áreas públicas.

Genel kullanım alanlarında ve yarı genel kullanıma açık alanlarda, hırsızlığa karşı korumalıdır.

Защита от грабежа для полупубличных и общественных помещений.

半公共或公共場所的防盜

公共及び半公共区域での盗犯防止

공공장소에서의 도난 방지

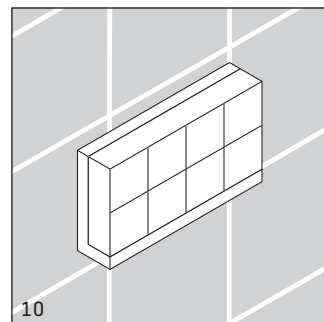
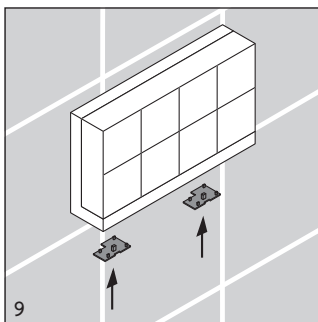
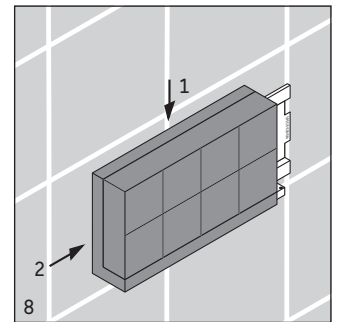
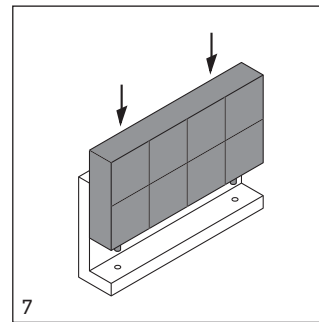
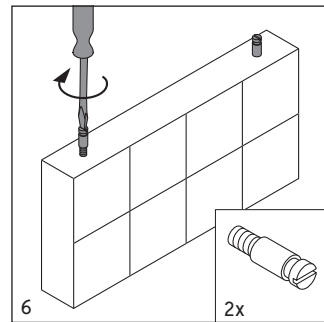
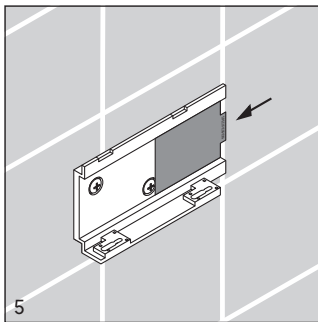
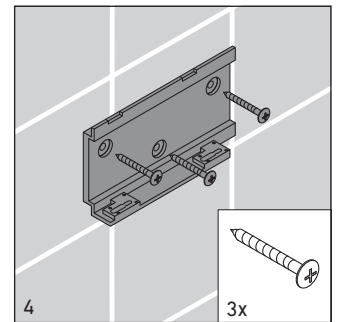
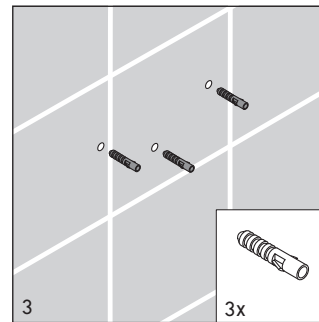
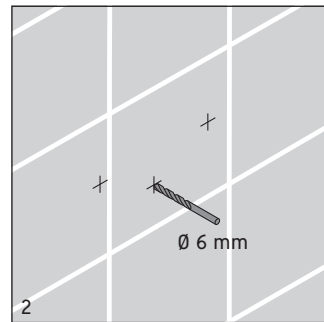
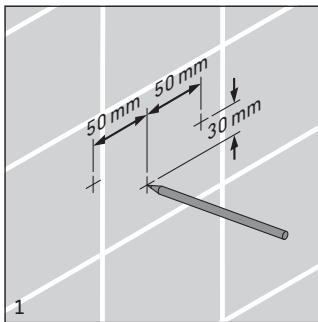

**Duravit AG**  
Werderstr. 36  
78132 Hornberg  
Germany  
Phone +49 78 33 70 0  
Fax +49 78 33 70 289  
info@duravit.de  
www.duravit.de

---

Technische Verbesserungen und optische Veränderungen an den abgebildeten Produkten behalten wir uns vor.  
We reserve the right to make technical improvements and enhance the appearance of the products shown.  
Nous nous réservons le droit d'apporter des améliorations techniques et de modifier l'apparence visuelle des produits présentés.  
Technische verbeteringen en optische wijzigingen ten opzichte van de afgebeelde producten voorbehouden.  
Con riserva di apportare modifiche tecniche.  
Nos reservamos el derecho de realizar modificaciones técnicas y de aspecto de los productos representados.  
Reservamo-nos o direito de efectuar melhorias técnicas e alterações visuais que beneficiem os produtos apresentados.  
Belirtilen ürünlerinde teknik iyileştirme ve görsel değişiklik yapma haklarımız saklıdır.  
Мы оставляем за собой технические улучшения и оптические изменения в отображенных изделиях.  
由于技术改进, 我们保留改变产品规格说明的权利。  
弊社は改良により製品の仕様・外観を変更する権利を有しております。  
당사의 사정에 따라 제품의 외관이나 제품에 적용된 기술이 개선될 수 있습니다.

